



General Manual

for Telemetry System
with Ex-Certification



Manner Sensortelemetrie GmbH
Eschenwasen 20
D-78549 Spaichingen

Telephone: +49 (0)7424 9329-0
Fax: +49 (0)7424 9329-29

E-mail: info@sensortelemetrie.de
Internet: www.sensortelemetrie.de

10001, 11, en_US

Revision history:

Document code	Date	Modification	Released
	2011-03	Creation of documentation	
	2011-04-08	Documentation released	
10001, 1, en_US	2011-06-21	Transfer to editing system (layout)	
10001, 2, en_US	2012-01-11	Documentation revised	
10001, 3, en_US	2012-03-28	Sensor signal amplifier, labeling, table 2 supplemented	
10001, 4, en_US	2013-08-20	Appendix A "EG Prototype Verification Certificate" added	
10001, 5, en_US	2014-02-14	Documentation revised	
10001, 6, en_US	2015-06-30	Documentation revised	
10001, 7, en_US	2016-04-20	Guideline 2014/34/EU	2016-04-20, Hafen
10001, 8, en_US	2016-06-17	1.5.4 Definition, Explosion Groups (row "Permitted Temperature classes") removed	2016-06-17, Hafen
10001, 9, en_US	2016-06-21	1.4 Special Hazard Hints, EN 62141-11 removed; note for 'X' for marking added	2016-06-21, Hafen
10001, 10, en_US	2023-10-06	New standard DIN IEC 60079:2018 & revision	2023-10-06, Kühn
10001, 11, en_US	2026-05-06	Revision of the Declaration of Conformity	2026-05-06, Kühn

Disclaimer

Trade marks and trade names were used without verification of the free applicability. The texts and examples were prepared with care. Mistakes can not be excluded. The enterprise Manner Sensortelemetrie will assume no liability for missing or incorrect information and resulting consequences, neither judicial nor otherwise.

The enterprise Manner Sensortelemetrie GmbH may change or upgrade hardware and software – or parts of them - as well as the provided documents (operation instructions, start-up instructions, spare parts lists) – or parts of them – without notification.

All rights for duplicating, photomechanical reproduction – also extracts - are explicitly reserved by the enterprise Manner Sensortelemetrie.

We would be glad for suggestion for improvement and notes about mistakes.

©May 2026, Manner Sensortelemetrie GmbH

Table of contents

1	Security	4
	1.1 Information about this Manual.....	4
	1.2 Definition of Warnings.....	4
	1.3 General Warnings.....	4
	1.4 Special Hazard Hints.....	6
	1.4.1 Avoidance of Electrostatic Charge.....	7
	1.4.2 Maximum Surface Temperature.....	7
	1.5 Definitions.....	7
	1.5.1 Declaration on Product Labels.....	8
	1.5.2 Zones Classification.....	8
	1.5.3 Product Declaration.....	8
	1.5.4 Definition of gases, vapors and dusts, Explosion Groups.....	9
	1.5.5 Temperature Classes, Dusts.....	9
2	Conventional Usage	10
3	Description of the Systems, Technical Data	13
	3.1 General Measuring Installation.....	13
	3.1.1 Principle.....	13
	3.1.2 Equipment Overview.....	14
	3.1.3 Energy and Data Flow.....	15
	3.2 Evaluation Unit.....	15
	3.2.1 Electrical Data Evaluation Unit.....	15
	3.2.2 Labeling.....	15
	3.2.3 Special Conditions of Use „X“ Evaluation Unit.....	16
	3.3 Coaxial Cable (Cable Z).....	17
	3.3.1 Requirements for the Coaxial Cable.....	17
	3.3.2 Connections / Cable Feedthrough	17
	3.4 Antennas and Interface.....	17
	3.4.1 PickUp Stator Antenna, General Information.....	17
	3.4.2 PickUp Stator Antenna, Labeling.....	19
	3.4.3 Special Conditions „X“ PickUp Stator Antenna.....	19
	3.4.4 Rotor Antenna.....	20
	3.5 Sensor Signal Amplifier.....	21
	3.5.1 General Information.....	21
	3.5.2 Sensor Signal Amplifier Labeling.....	22
	3.5.3 Special Conditions „X“ Sensor Signal Amplifier.....	23
	3.6 Compact Evaluation Unit.....	23
	3.6.1 General Information.....	23
	3.7 Evaluation Unit in Tube Housing.....	24
	3.7.1 General Information.....	24
	3.8 Tabletop Unit for Multichannel Systems.....	25
	3.8.1 General Information.....	25
4	Installation Guide	26
	4.1 Preparation for Mounting.....	26
	4.2 Installation of the PickUp Stator Antenna.....	26
	4.3 Installation of the Sensor Signal Amplifier.....	26
	4.4 Installation of the Evaluation Unit.....	27
	4.5 Installation of the Grounding and Potential Equalization.....	27
	4.6 Dismounting of the Sensor Telemetry System.....	27
5	Further Information	28
6	Contact	29
	Appendix	30
	A Declaration of Conformity.....	31

1 Security

1.1 Information about this Manual

This manual allows the safe and efficient handling of the delivered components. The manual is part of Manner Sensor Telemetry System and must be kept accessible for the personnel at all times in the immediate vicinity of the system. The personnel must also be incorporated in accordance with the documents of the entire system. Personnel must carefully read and understand the required instructions before starting work. Basic prerequisite for safe working is the observance of all specified safety and handling instructions. In addition, the local accident prevention regulations and general safety regulations must be applied. Illustrations in this manual are provided for basic understanding and may differ from the actual design.

1.2 Definition of Warnings



DANGER!

Hint for possible dangerous situation. Ignoring the security terms may cause dead or serious injury.



WARNING!

Hint for possible dangerous situation.
Ignoring the security terms may cause injury.



DANGER!

Important hints for usage in areas exposed to explosion hazards.



CAUTION!

Hint for possible loss of property, if the corresponding protective measure were disregarded.



Further information

1.3 General Warnings

The system startup has to be made by instructed qualified personnel, who is able to estimate the potential risks. It is a matter of course that all chapters of these original instruction manual were read and understood completely before startup.

In the event of non-observance, the manufacturer is not entitled to compensation for the damage caused. Each kind of change of the system, except the described operations in the instruction manual and customer documentation, causes a disclaimer of warranty.

The on hand instruction manual contains all ATEX specific information for a prompt startup and a safe operation.

Manner Sensortelemetrie is a supplier of equipment to the operator and has no effect on the final application.

The operator is obliged to have the entire system checked for explosion safety by a notified body.

**DANGER!****Risk of Injury by Faulty Installation**

An incorrect installation may immediately cause injury to persons during the installation or during the subsequent starting.

Mind the built-up instruction (see chapter 4, mounting instruction) and the customer documentation

The System must be installed and brought on line by authorized qualified personnel which

- is familiar with the professional handling of safety components and
- the valid directive for operational safety and rules for accident prevention.

**DANGER!****Risk of Injury by Unintentional Beginning of Operation**

Rotating or movable parts may cause injury while unintentional beginning of operation.

Set the system currentless while all mounting, dismounting or repair work. Mind the installation instruction.

**DANGER!****Risk of Injury by Movable Parts**

While the regular operation as well as by unintentional releasing of parts of the telemetry system while operating present persons may be injured because if missing protection equipment.

Check the assured function of the protection equipment particularly

- before each bringing into service
- after each replacement of components
- after a longer standstill
- after each fault.

Independent of this the assured function of the protection equipment should be checked in appropriate time interval as a part of the maintenance work!

**WARNING!****Risk of Injury by Burning**

While operating the sensor signal amplifier and the PickUp stator antenna may heat up.

Avoid contact.

**CAUTION!****Risk of Damage to Property**

If connectors are plugged-in or pulled while voltage is present the telemetry system itself as well as connected devices may be damaged.

Do not plug-in or pull connectors while voltage is present.

WARNING!
Explosion Protection

Identifies contents and instructions in this manual that apply to the ATEX directive the use of this machine in hazardous areas. Inobservance of these contents and instructions can lead to loss of explosion protection.

1.4 Special Hazard Hints

DANGER!

The EX variant of sensor telemetry systems is only suitable for following cases of operation

- in areas with risk of gas explosion: zone 2, 1
- in areas with risk of dust explosion: zone 22, 21

During operations as mounting or electrical installation it has to be guaranteed that

- a working approval was given by the operator
- no explosive atmosphere is present
- the system is power off

DANGER!

To avoid dangerous increase of temperature on the surfaces prevent dust deposits (cover, regular cleaning)

The following current standards are for the system to use: "intrinsic safety ib"

NOTICE!

You should have access to following current directives if required:

Directive 2014/34/EU (ATEX)

You should have access to following current standards if required:

EN 1127-1 explosion prevention – basic information and methodology

Standards for intrinsically safe equipment for use in:

- **potentially explosive gas atmospheres ("G")**
- **In areas with combustible dust ("D")**

EN 60079-0 General requirements

EN 60079-10 Classification of areas exposed to explosion hazards

EN 60079-11 Device protection by intrinsic safety

EN 60079-14 Explosible atmosphere; project planning, selection and installation of electrical installations

EN 60079-25 Explosive atmospheres - Intrinsically safe systems

Check for other applicable harmonized standards under Directive 2014/34/EU (ATEX) in the "Official Journal of the European Union".

Furthermore, the TRBS rules have to be followed.

1.4.1 Avoidance of Electrostatic Charge



Instructions to the operator:

To evaluate the present resources in order to avoid electrostatic charging according to DIN EN 60079-0 Chapter 7.4, the following information:

Group II (Gas)

Non-metallic surfaces (e.g. by grouting of rotor loop) are rated "by limiting the surface of non-metallic housing parts", DIN EN 60079-0, table 6 and 7. The specified values in table 6 must be increased by a factor of 4, if the non-metallic surfaces are framed by metallic, and it is assumed that the metal parts are grounded.

Group III (Dust)

The areas covered by the potting compound are also evaluated, as for gas, according to EN 60079-0, tables 6 and 7, since it can be assumed that charge carriers cannot be stored in sufficient energy due to the metallic frame.

The operator is responsible for further measures / assessments to avoid electrostatic charge.

1.4.2 Maximum Surface Temperature

The designation of the maximum surface temperature has been determined without regard to a layer of dust respectively with free heat emission. If the heat emission is interrupted e.g. by a layer of dust or cover, appropriate measures must be taken by the operator!

1.5 Definitions



NOTICE!

The operator is responsible for the correct classification of hazardous areas!

The following tables must be checked / verified with the valid standards.

1.5.1 Declaration on Product Labels

Declaration

Gases:

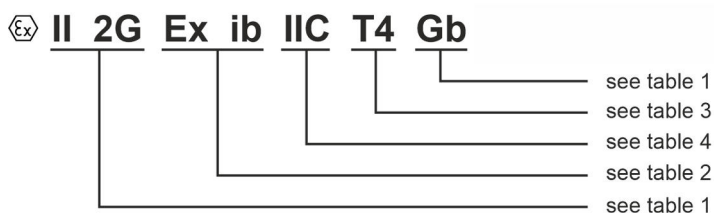

Dusts:

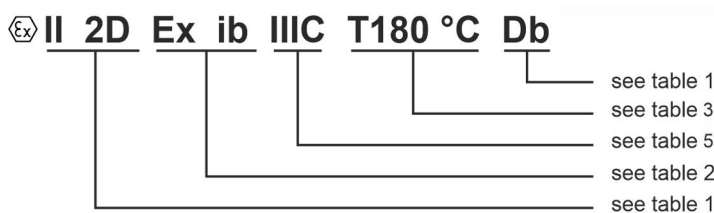

1.5.2 Zones Classification

Terms and Classification			Required Labeling of Operating Resource			
Flammable substance	Temporary behavior of the explosive atmosphere	Classification areas exposed to explosion hazards	Group in sense of RL 2014/34/EU	Machine category in sense of RL 2014/34/EU	Group in sense of RL 2014/34/EU	Machine safety level (EPL) in sense of EN 60079-0
Gases, vapor	Is always, long-term or frequently present	Zone 0	II	1G	II	Ga
	During normal operation casual present	Zone 1	II	2G or 1G	II	Gb or Ga
	Typically not during normal operation casual present, or just short-term	Zone 2	II	3G or 2G or 1G	II	Gc or GB or Ga
Dusts	As cloud always, long-term or frequently present	Zone 20	II	1D	II	Da
	As cloud casual present during normal operation	Zone 21	II	2D or 1D	II	Db or Da
	As cloud typically not or just short-term present during normal operation	Zone 22	II	3D or 2D or 1D	II	Dc or Db or Da
Methane, carbon dust	Running at explosion hazard	-	I	M1	I	Ma
	Shutdown at explosion hazard	-	I	M2 or M1	I	Mb or Ma

1.5.3 Product Declaration

Use	Flammable substance	Safety principle	Ignition protection type	Labeling according to the machine safety level		
				a = very high safety	b = high safety	c = hightend safety
All uses	Gases, vapors and dusts	-	General requirement	-	-	-
switching devices, controls, motors, command and signal units, power electronics	Gases and vapors (G)	Transfer to outside of an explosion is excluded	Pressure-resistant casing	-	Ex d Ex db	-
Junction and conjunction boxes, enclosures, motors, lamps, terminals	Gases and vapors (G)	Avoid spark and temperature	Hightend Safety	-	Ex e Ex eb	-
Junction and conjunction boxes, enclosures, motors, lamps, switch and control cabinet	Vapors (D)	Keep explosive dust atmosphere away from ignition source	Safety by enclosure	Ex ta	Ex tb	Ex tc
measurement device and regulation technology, sensors, actuators, instruments	Gases and vapors (G)	Energy limitation of spark and temperature	Intrinsic safety	Ex ia	Ex ib	Ex ic
	Vapors (D)			Ex ia	Ex ib	Ex ic
Switch and control cabinet, motors, measurement device and analyzer, data processor	Gases and vapors (G)	Keep explosive dust atmosphere away from ignition source	over pressure casing	-	Ex px Ex py Ex pyb	Ex pz Ex pzc
	Vapors (D)				Ex pb Ex pyb	Ex pc
Inductors and relays of motors, electronic, solenoid valve, connection systems	Gases and vapors (G)	Keep explosive dust atmosphere away from	grouting casing	Ex ma	Ex mb	-
	Vapors (D)			Ex ma	Ex mb	-
Power transformers, relays, run-up control, switching device	Gases and vapors (G)	Keep explosive dust atmosphere away from ignition source	Oil casing	-	Ex o Ex ob	-
Power transformers, relays, capacitors	Gases and vapors (G)	Transfer to outside of an explosion is excluded	Sand casing	-	Ex q Ex qb	-
All uses in zone 2	Gases and vapors (G)	All ignition protection principles customized for zone 2	Ignition protection type "n"	-	-	Ex nA Ex nC Ex nR Ex nL Ex nAc Ex nCc Ex nRc Ex nLc

1.5.4 Definition of gases, vapors and dusts, Explosion Groups

Table 3 - Subdivision of Gases and Dusts					
Gases and dusts			classification of gases and dusts by ignition temperature	Temperature class	maximum surface temperature of the machine
ammonia, methane, ethane, propane	city gas, acrylonitrile	hydrogen	>450°C	T1	450°C
ethyl alcohol, cyclohexane, n-butane	ethene, ethylene oxide	ethine (acetylene)	>450°C ... <300°C	T2	300°C
benzine (general), injector fuel, n-hexane	ethylene glycol, hydrogen sulfide		>200°C ... <300°C	T3	200°C
acetaldehyde	ethyl ether		>135°C ... <200°C	T4	135°C
			>100°C ... <135°C	T5	100°C
		carbon disulfide	>85°C ... <100°C	T6	85°C

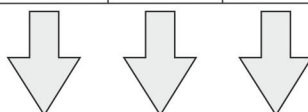

Table 4 - Explosion Groups		
IIA	IIB	IIC
Permitted machine groups		
IIA, IIB, IIC	IIB, IIC	IIC

Table 5 - Dust Groups		
Labeling	Dusts	Permitted machine
IIIA	flammable fibrous material	IIA, IIB, IIC
IIIB	non conductible dust	IIB, IIC
IIIC	conductible dust	IIC

1.5.5 Temperature Classes, Dusts

Table 6 - Ignition temperature of Dusts	
Permitted temperature dust deposit	$T_{\text{perm.deposit}} = T_{5\text{mm deposit}} - 75^\circ\text{C}$
Permitted temperature dust cloud	$T_{\text{perm.cloud}} = \frac{2}{3} T_{\text{cloud}}$
Maximum permitted surface temperature of the machine	$T_{\text{perm.deposit}} \geq T_{\text{perm.}} \leq T_{\text{perm.cloud}}$

2 Conventional Usage

Sensor Telemetry Systems are used for contact-free tapping of passive sensor signals (e.g. on rotating shafts).

The delivered system has to be used **exclusively** for the prescribed measurement or control task.



CAUTION!

The operator has to take care himself in case of failure malfunction, e.g. overload



DANGER!

It is not permitted to open the enclosures of the intrinsically safe equipment!

A telemetry system contains:

- Evaluation unit
- Pickup stator antenna
- Sensor signal amplifier



NOTICE!

It is not allowed to connect products of foreign manufacturers

The mixing of Ex and non Ex products is not allowed!

For permitted component types for the Ex area mind overview Fig. 2

Liability Limitation

All information and instructions in this manual has been compiled in accordance with current standards and regulations, the state of the art and our many years of knowledge and experience.

The manufacturer assumes no liability for damages due to:

- Not following the guidelines
- Improper use
- Employment of untrained staff
- Unauthorized modifications
- Technical changes
- Use of unauthorized spare parts

The agreed commitments of the delivery contract, the general terms and conditions and the conditions of the manufacturer and the valid at the time the contract legal regulations are applied.

We reserve the right to make technical changes in the context of improving the usage properties and further ahead.

Spare Parts



DANGER!

Important notes for use in potentially explosive atmospheres.

Therefore:

- Use only original spare parts from the manufacturer or explicitly authorized by the manufacturer spare parts.
- In case of doubt always contact the manufacturer. Failure to follow these instructions will lead to loss of explosion protection.

Operator Responsibility

The supplied components are used by the operator or supplier in the appropriate end use. In addition to the safety instructions in this manual that apply to the application area of machine safety, accident prevention and environmental protection rules must be respected.

This is particularly:

- The operator must be aware of the applicable health and safety regulations and determine in a risk assessment other hazards that may arise from the special working conditions at the plant. This must be implemented in the form of an operating instruction.
- The operator must check during the entire period of use whether the operating instructions drawn up by him represents the current state of the regulations and adjust them if necessary.
- The operator has to define and regulate the responsibilities for installation, operation, maintenance and cleaning.
- The operator must ensure that all employees have been instructed appropriate.
- The operator is responsible for creating a risk assessment.

Loss of Explosion Protection



DANGER!

For systems designed for use in hazardous areas according to directive 2014/34/EU the operator must ensure compliance with the directive for the entire plant. Ignoring leads to the loss of explosion protection.

Unauthorized Persons



WARNING!

Danger to unauthorized persons!

Unauthorized persons who do not meet the requirements described here, do not know the hazards in the workspace.

Therefore:

- Keep unauthorized persons away from the workspace.
- If in doubt ask and relegate people from the workspace.
- Interrupt work as long as unauthorized persons stay in the workspace.

Instruction

Personnel must be instructed by the operator regularly.

Transport / Storage



WARNING!

Transport damage can lead to loss of explosion protection.

- In case of visible transport damage to the components, do not put them into operation. Contact the manufacturer.

Failure will lead to loss of explosion protection.

**CAUTION!**

Instructions for storing the components:

- No outdoor storage
- No expose to aggressive substances

3 Description of the Systems, Technical Data

3.1 General Measuring Installation

3.1.1 Principle

The Sensor Telemetry System is used for contact-free tapping of passive sensor signals.

It consists of the evaluation unit, the pickup stator antenna and the sensor signal amplifier.

Together with the power supply, the sensors and the connection cables they form the entire system. Evaluation unit, pickup stator antenna and sensor signal amplifier are reviewed and audited from a prototype.

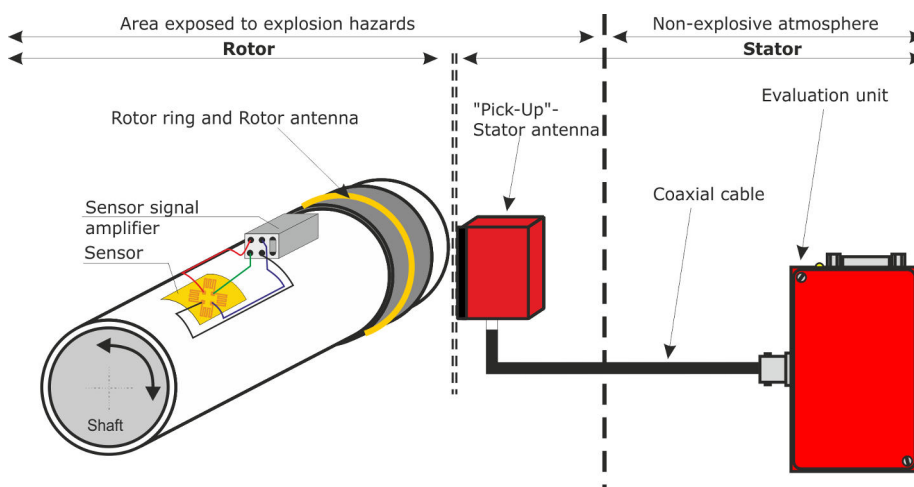

Fig. 1: Measuring installation, principle

Decription Measuring System

The evaluation unit is situated outside of the area exposed to explosion hazards as related intrinsically safe operating resources - and performs two tasks: It is the HF source and receiver of the sensor data.

The pickup stator antenna is situated inside the area exposed to explosion hazards and is connected to the evaluation unit by a coaxial cable. The energy of the HF source is transformed into a magnetic field by the pickup stator antenna. The energy supply of the sensor signal amplifier as well as the passive sensors is contactless by inductive linking. The HF energy is tapped by an induction loop and is delivered to the sensor signal amplifier. The sensor signal amplifier generates the supply voltage for the sensors and the internal electronics from the HF voltage and modulates the measuring signal on the HF voltage.

Foreign Components

The running of system components of foreign manufacturers is not permitted. Exceptions are cables and sensors. The evaluation unit is part of the evaluation system and is installed mechanically and electrically inside of it. The coaxial connector is leaded directly outward (without adapter) during the installation and provides a good accessibility for the customer.

From the connector a coaxial cable leads to the potentially explosive area.

The power supply of the evaluation unit is inside the evaluation system, by using the Sub-D9 interface situated inside the evaluation system. The digital data of the Sub-D9 interface are converted into a output signal as predefined by the customer, e.g. into an analog signal or a digital USB signal.



Note

The evaluation unit must be grounded by the operator via the intended grounding point or connected to the potential equalization.

3.1.2 Equipment Overview

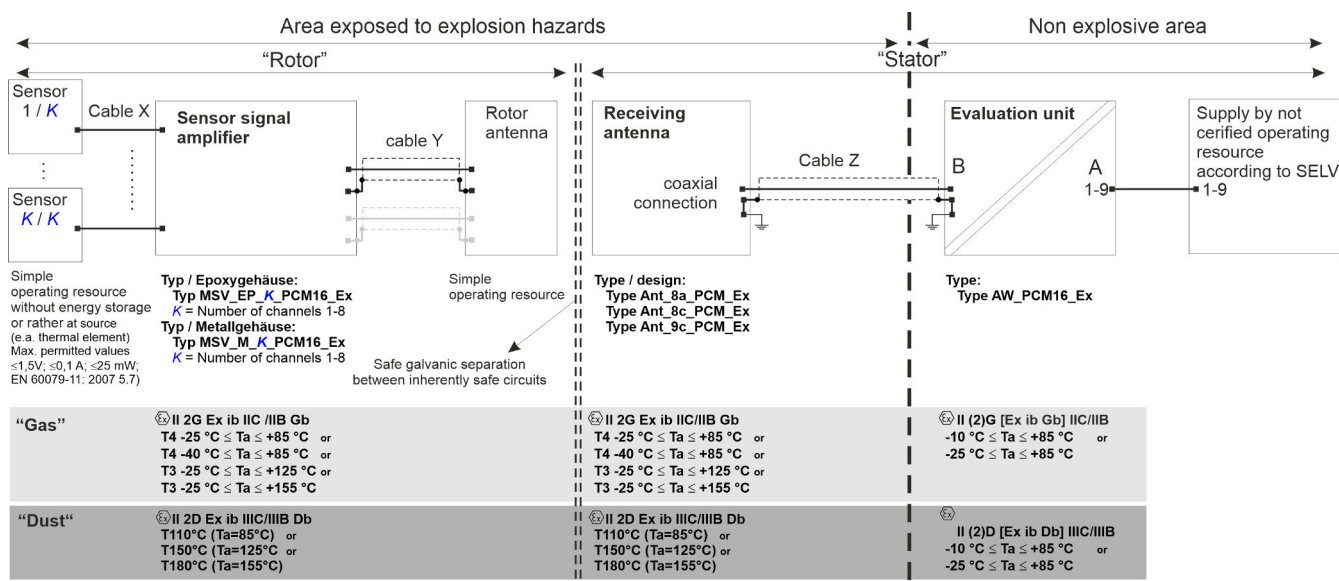

Fig. 2: Equipment overview

Remark

Since the intrinsically safe HF output circuit is grounded under normal operating conditions, potential equalization must be carried out along the cable routing of the HF measuring circuit inside and outside the potentially explosive atmosphere.

Design, frequency and number of channels have no influence to the EX- safety / parameter because they were correspondingly reviewed.

Temperature declarations and range represent ordering options, as well as the applications for IIC/IIB or IIIC/IIIB.

For the definite declaration and temperature range mind the type labels of the respective equipment rather as the provided customer documentation.

Mind the provided manual and the customer documentation for special conditions.

The operator is responsible for the ignition source analysis of the complete equipment.

3.1.3 Energy and Data Flow

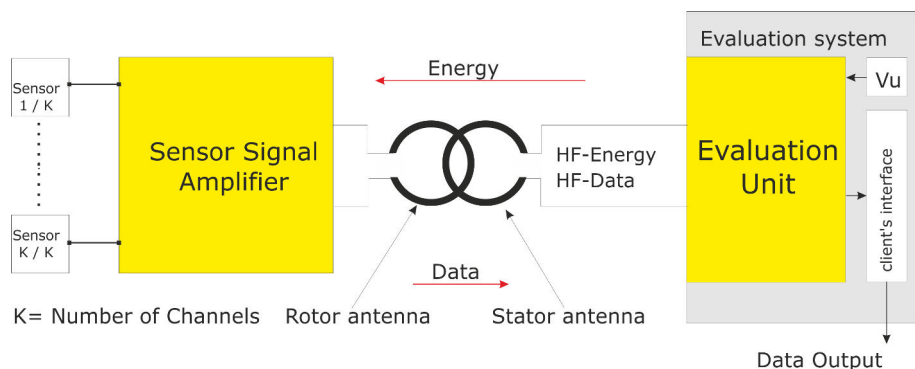

Fig. 3: Energy and Data Flow

3.2 Evaluation Unit

3.2.1 Electrical Data Evaluation Unit

The evaluation unit is factory-provided integrated into a compact evaluation unit or a tabletop unit. The supply of the evaluation unit is internally generated according to EN 60950 with $15V \pm 2\%$.

HF-voltage (transfer interface to the Ex-area)

The HF voltage is generated by a HF output stage and is securely separated from the other circuit parts by capacitors or rather insulating clearances. The supply of the HF output stage as well as the HF output voltage are securely delimited by voltage delimiting measures. The frequency of the HF voltage is denoted with f_{sys} . The stator antenna and the sensor signal amplifier must be constructed for the same frequency f_{sys} . The usage of components with different frequency f_{sys} is not expedient, but not security relevant.

3.2.2 Labeling

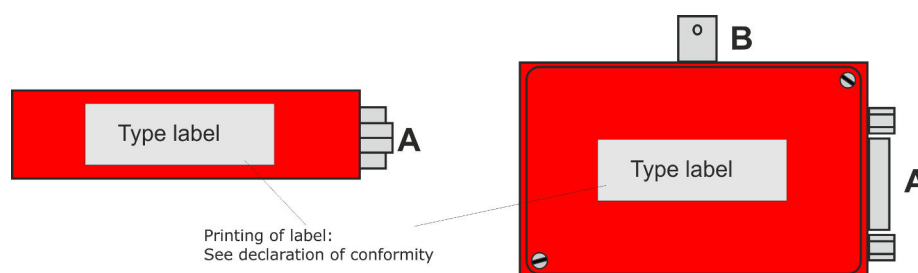

Fig. 4: Labeling of the evaluation unit

The Ex-relevant parameters are affixed on the box' side, because the top cover is not combined undetachably with the enclosure! Additional general values are stated on the top cover.

Because the evaluation unit is situated in an additional enclosure, an extra labeling with all parameters is affixed outside the end device, inclusive the cc -labeling for the complete telemetry system.

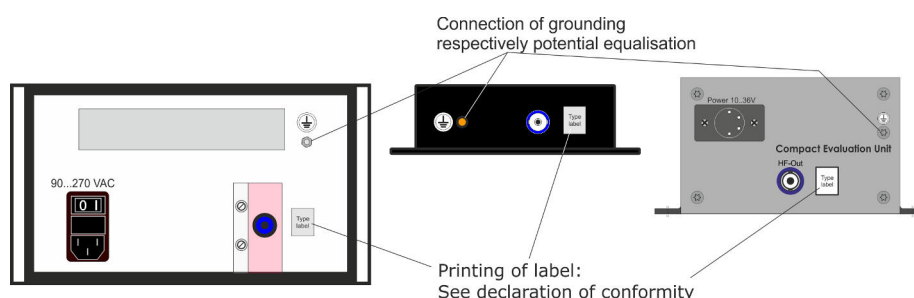

Fig. 5: Labeling tabletop unit or compact unit

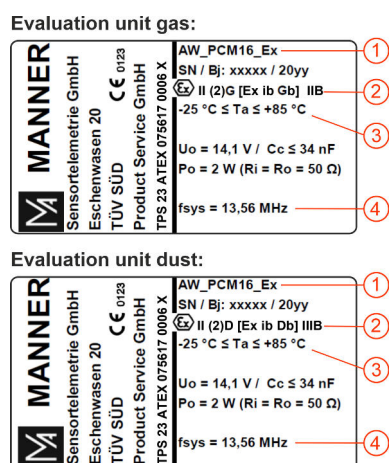

Fig. 6: Labeling evaluation unit

1	Possible type identifier:	
	AW_PCM16_Ex	
2	Identifier for explosive gas atmosphere:	Identifier for explosive dust atmosphere:
	Ⓔ II (2)G [Ex ib Gb] IIC	Ⓔ II (2)D [Ex ib Db] IIIC
	Ⓔ II (2)G [Ex ib Gb] IIB	Ⓔ II (2)D [Ex ib Db] IIIB
3	Temperature range:	Temperature range:
	-25°C ≤ Ta ≤ +85°C	-25°C ≤ Ta ≤ +85°C
	-10°C ≤ Ta ≤ +85°C	-10°C ≤ Ta ≤ +85°C
4	Variants system frequency f_{sys}	
	13.56 MHz	
	6.78 MHz	
	3.39 MHz	

3.2.3 Special Conditions of Use „X“ Evaluation Unit

- Since the intrinsically safe HF output circuit is grounded under normal operating conditions, potential equalization must be carried out along the cable routing of the HF measuring circuit inside and outside the potentially explosive atmosphere.
- In the type of protection intrinsically safe "ib" only provided for connection to the PickUp stator antenna of Manner Sensortelemetrie GmbH, type Ant_8a_PCM_Ex or type Ant_8c_PCM_Ex or type Ant_9c_PCM_Ex coaxial cable with typ. impedance 50Ω !
- The evaluation system (e.g. table top unit, compact unit) in which the evaluation unit is integrated must be grounded in compliance with standards.
- The supply of the evaluation unit must be made through a supply according to EN 60950!
- The evaluation unit is located outside of the hazardous area, the HF circuit is fed by a coaxial cable into the Ex area.
- The housing of the evaluation unit may only be opened by instructed and trained personnel!

**CAUTION!**

The evaluation system which contains the evaluation unit, must be grounded.

**NOTICE!**

The shield of the BNC plug (B) and the housing is connected with the GND pin/s of the D-Sub plug (A)!

3.3 Coaxial Cable (Cable Z)

The cable connection between the pickup stator antenna and the evaluation unit is performed by a coaxial cable (cable Z).

3.3.1 Requirements for the Coaxial Cable

The used coaxial cable must fulfill following properties:

- Surge impedance 50Ω
- Maximum capacity for the complete cable length $C_C \leq 34 \text{ nF}$
- Maximum inductance $L_C \leq 100 \mu\text{H}$

A coaxial cable 4m RG400 (100 pF/m, 250 nH/m) is by default fix performed with the pickup stator antenna. According to the customer specification a longer cable can be provided, so the high temperature range ($\leq 155^\circ\text{C}$) can be left without inter-connection.

A cable gland can be added on the cable during production according to the customer specification, so a feedthrough according to EN 60079-0 can be performed. Longer distances should be realized with low loss cable to the evaluation unit.

3.3.2 Connections / Cable Feedthrough

**NOTICE!**

For any connections inside a gas atmosphere a protection class $\geq \text{IP} 54$, for dust $\geq \text{IP} 65$ is recommended.

On connections following notice should be added:

- „Do not disconnect or connect when the system is powered on“
- „Do not disconnect or connect in areas exposed to explosion hazards“

At the passage between different zones the necessary cable feedthrough has to be realized according to EN 60079-0.

3.4 Antennas and Interface

3.4.1 PickUp Stator Antenna, General Information

The pickup stator antenna is part of the sensor telemetry system and is connected to the evaluation unit by the coaxial cable.

The transition from the non-explosive atmosphere to the area exposed to explosion hazards has to be executed according to EN 60079-0 for cable insertion.

The antenna is situated in the hazardous area and transmits the energy to the rotor ring contactlessly by inductive coupling. The pickup stator antenna generates a magnetic field from the HF voltage and induces the energy contactlessly into the induction loop (rotor antenna). There is no d.c. voltage generated inside the pickup stator antenna.

The pickup stator antenna is offered in several enclosure designs. The EX relevant internal circuit of the different antennas is identical.

The selection of the antenna type depends on the available space in the application. The model type 9c offers the highest efficiency, followed by type 8c and type 8a.

The choice of the system frequency „ f_{sys} “ (13.56 MHz, 6.78 MHz and 3.39 MHz) is made for the complete system. The interconnection of system components with different system frequencies does not make sense, but has no impact to the intrinsic safety.

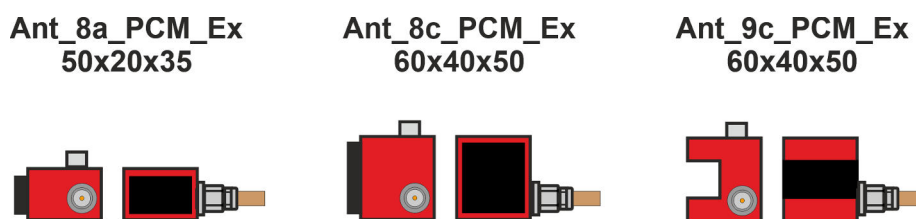
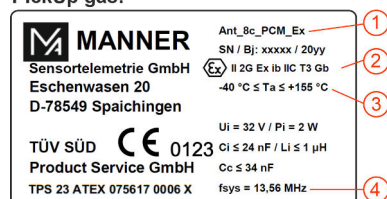

Fig. 7: Different antenna formats of pickup stator antennas

By using an alignment coil the intern oscillating circuit is calibrated on resonance. The enclosure is made from aluminum and completely filled with potting compound. The HF output power of the evaluation unit is limited to max. 2 W. In case of failure the receiving antenna has 2 W power loss. The complete heat of the antenna is given to the environmental air over the surface of the aluminum enclosure.

3.4.2 PickUp Stator Antenna, Labeling

PickUp gas:



PickUp dust:

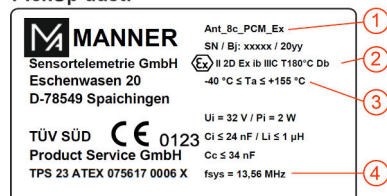

Fig. 8: Labeling of the pickup stator antenna

1	Possible type identifier:
	Ant_8a_PCM_Ex
	Ant_8c_PCM_Ex
	Ant_9c_PCM_Ex

2	Identifier for explosive gas atmosphere:	Identifier for explosive dust atmosphere:
	II 2G Ex ib IIC Gb	II 2D Ex ib IIIC Db
	II 2G Ex ib IIB Gb	II 2D Ex ib IIIB Db

3	for following temperature range:	for following temperature range:
	T4: Ta ≤ +85°C	T110 °C (Ta = 85°C)
	T3: Ta ≤ +125°C	T150 °C (Ta = 125°C)
	T3: Ta ≤ +155°C	T180 °C (Ta = 155°C)

4	Variants system frequency f _{sys}
	13.56 MHz
	6.78 MHz
	3.39 MHz



U_i, P_i, C_i, C_c, L_i etc. for all types / variants identical because these values stand for the maximum values at worst case for all variants.

3.4.3 Special Conditions „X“ PickUp Stator Antenna

- The operator is responsible for the final ignition source analysis of the complete system!
- Since the intrinsically safe HF output circuit is grounded under normal operating conditions, potential equalization must be carried out along the cable routing of the HF measuring circuit inside and outside the potentially explosive atmosphere.
- In type of protection intrinsic safety "ib" only for connection to the evaluation unit from Manner Sensortelemetrie GmbH, type AW_PCM16_Ex via coaxial cable with typ. surge impedance 50 Ω!
- The pickup stator antenna type Ant_9c_PCM_Ex ist only allowed to use together with rotor antenna „U-shaped“!
- Avoid categorically a mechanical contact between rotor antenna and stator antenna!
- The maximum length of the coaxial cable is delimited by C_c and L_c of the pickup stator antenna.
- The rotor antenna consists of max. one turn with diameter of ≥78 mm (type "saddle"), respectively ≥33 mm (type "Flat"). Deviating from this a new validation is necessary.

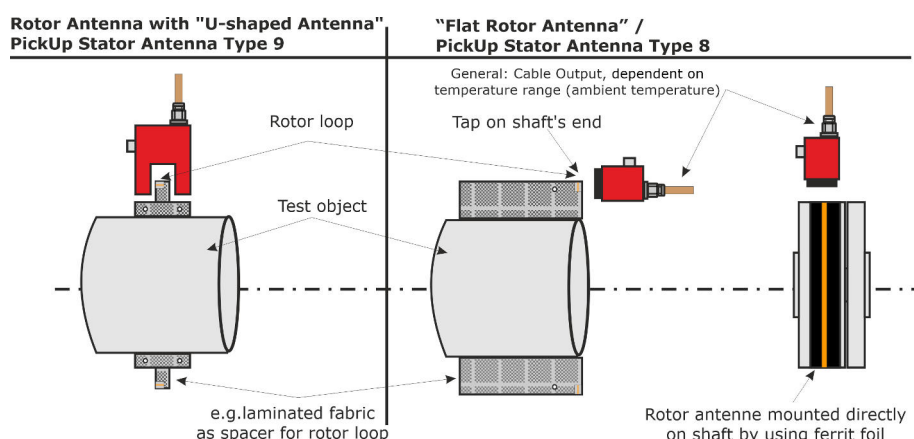

Fig. 9: Antenna coupling

NOTICE!
 The pickup stator antenna must factory-provided always be mounted and fixed to avoid mechanical contact during the running. Sensor signal amplifier and sensors are fixed on or rather inside the test object.

3.4.4 Rotor Antenna

Each pickup stator antenna belongs to a corresponding rotor antenna:

Rotor antenna "Flat"

(e.g. for Pickup Stator antenna 8)

Rotor antenna "Disk"

(e.g. for Pickup Stator antenna 9)

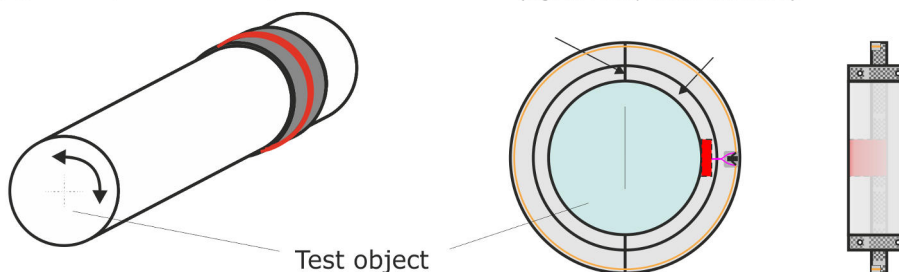

Fig. 10: Design forms of the rotor antenna

The rotor antenna contains only the induction loop and does not heat up. The inductance of the induction loop can be neglected from a safety perspective (0.01 mH). The system is adapted respective it's performance by using a trimmer (≤ 2.2 nF). The induction loop consists only of one turn.

In consequence of the design of the coupling the maximum output at the rotor side is 1.2 W. The rotor loop is connected to the sensor signal amplifier as short as possible.

The rotor antenna has to be protected against mechanical impacts by using appropriate measures such as grouting. The electrostatic charging of non-metallic areas must be reviewed according to EN 60079-0, when indicated the test object must be grounded.

For metallic test objects it is generally recommended to ground them to avoid electrostatic charging beneath the covered rotor loop and the measuring point.

3.5 Sensor Signal Amplifier

3.5.1 General Information

The sensor signal amplifier is located together with the rotor antenna on the rotating part of the telemetry measuring system. A rotation is not obligatory required for the function. The data and the power are transmitted via inductive coupling.

Only passive sensors or thermocouples without energy storage (≤ 1.5 V; ≤ 0.1 A; ≤ 25 mW) may be connected to the Sensor signal amplifier. The inner inductance is insignificant. The cable (cable Y) between rotor antenna and sensor signal amplifier is fix connected and either sealed or fixed to the enclosure by screwing. All components on the rotor side must be fixed (e.g. welding strap or sealing) according to the mechanical forces.



For the valid pin assignment for the sensors take note of the respective customer documentation!

3.5.2 Sensor Signal Amplifier Labeling

Sensor signal amplifier gas:



Sensor signal amplifier dust:



Fig. 11: Labeling of the sensor signal amplifier

1	Possible type identifier:
	MSV_EP_K_PCM16_Ex
	MSV_M_K_PCM16_Ex
	MSV_EP_1_RMC16_Ex
	MSV_M_1_RMC16_Ex
	K = number of channels 1-8 and corresponding box size / form: EP = epoxy box M = metal box

2	Identifier for explosive gas atmosphere:	Identifier for explosive dust atmosphere:
	Ex II 2G Ex ib IIC Gb	Ex II 2D Ex ib IIIC Db
	Ex II 2G Ex ib IIB Gb	Ex II 2D Ex ib IIIB Db

3	for following temperature range:	for following temperature range:
	T4: Ta ≤ +85 °C	T110 °C (Ta = 85°C)
	T3: Ta ≤ +125 °C	T150 °C (Ta = 125°C)
	T3: Ta ≤ +155 °C	T180 °C (Ta = 155°C)

4	Possible values
	U _o = 5.3 V / I _o = 353 mA
	U _o = 5.7 V / I _o = 316 mA
	U _o = 6.1 V / I _o = 295 mA
	U _o = 6.6 V / I _o = 273 mA

5	Variants system frequency f_{sys}
	13.56 MHz
	6.78 MHz
	3.39 MHz

U_i, P_i, C_i, C_c, L_i etc. for all types / variants identical because these values stand for the maximum values at worst case for all variants.

3.5.3 Special Conditions „X” Sensor Signal Amplifier

- The operator is responsible for the final ignition source analysis of the complete system!
- Only for installation with:
 - passive sensors without energy storage or rather
 - active sensors, e.g. thermocouples (sources with $\leq 1.5\text{ V}$; $\leq 0.1\text{ A}$; $\leq 25\text{ mW}$ are possible)
- Heat dissipation from the sensor signal amplifier must be guaranteed.
- In the type of protection intrinsic safety „ib” with a max. HF power of 1.2 W (rotor sided) only with EX equipment by Manner Sensortelemetrie.

3.6 Compact Evaluation Unit

3.6.1 General Information

The evaluation unit will be embedded into an extra enclosure. The digital data will be converted e.g. into analog measuring values or will be formatted for a digital connection. The system is internally equipped with a DC/DC converter to support a wide supply voltage range.

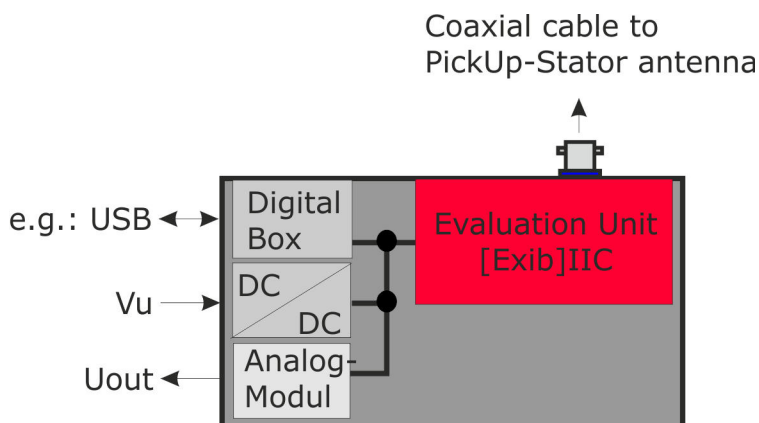

Fig. 12: Compact evaluation unit (schema)

The following figure is an example - the exact description can be found in the customer documentation.

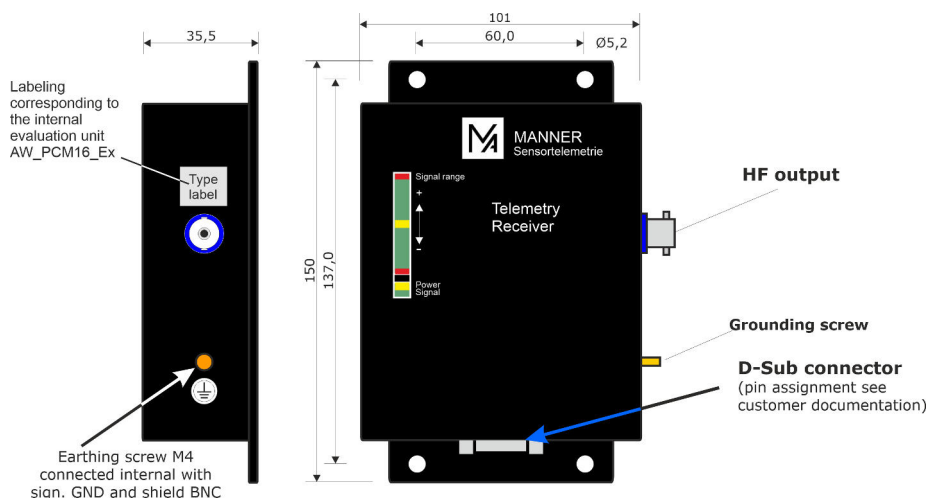

Fig. 13: Compact unit (dimensions and connections)

3.7 Evaluation Unit in Tube Housing

3.7.1 General Information

The evaluation unit will be embedded into an extra enclosure. The digital data will be converted e.g. into analog measuring values or will be formatted for a digital connection. The system is internally equipped with a DC/DC converter to support a wide supply voltage range.

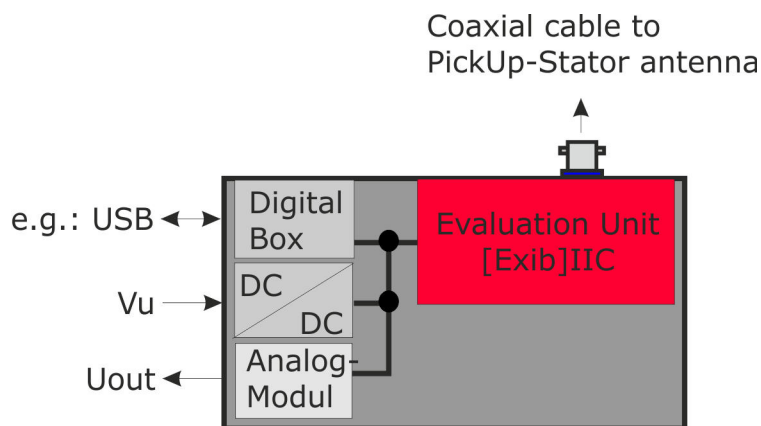

Fig. 14: Compact evaluation unit (schema)

The following figure is an example - the exact description can be found in the customer documentation.

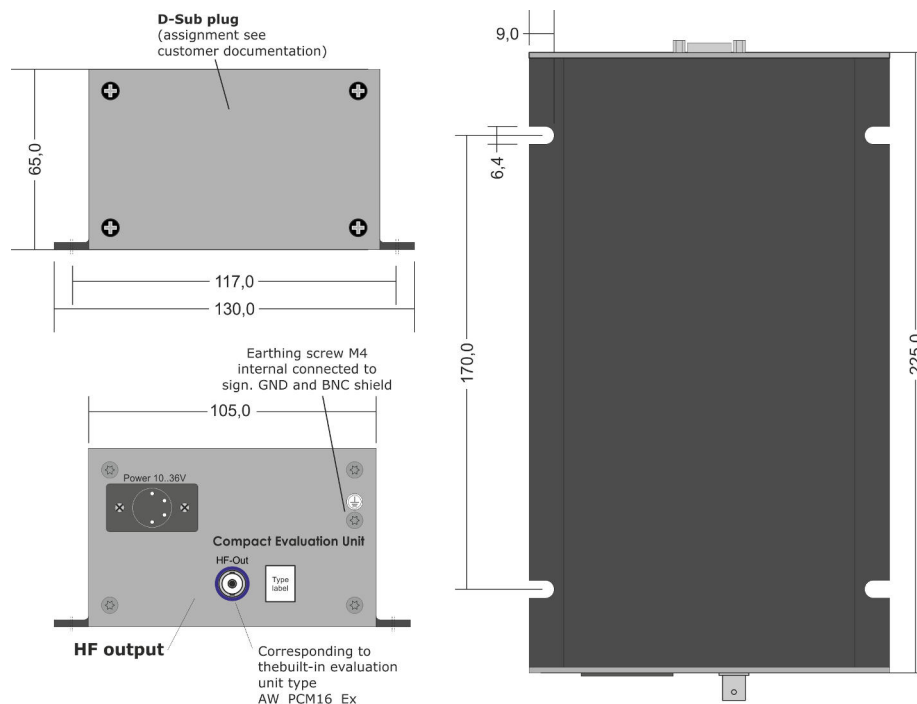

Fig. 15: Evaluation unit in tube housing (dimensions and connections)

3.8 Tabletop Unit for Multichannel Systems

3.8.1 General Information

The evaluation unit will be mounted with a bracket inside the tabletop unit at the rear panel. When powered on the evaluation unit will be supplied by an internal power pack. For analysis there are multiple analog test ports available, dependent on the system. Further different digital interfaces can be optionally provided.

The following illustration is an example. The exact representation is part of the customer documentation.

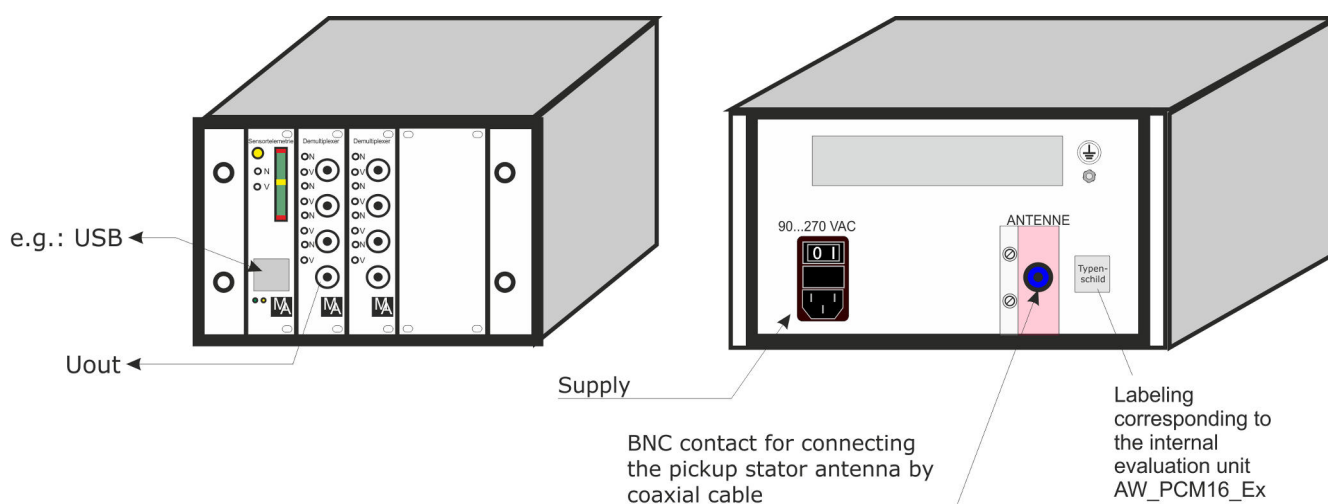

Fig. 16: Example for tabletop unit, front and back view



The customer-specific appearance and alignment can be different from Fig. 16 - note customer documentation

4 Installation Guide

4.1 Preparation for Mounting



DANGER!

Before mounting in area exposed to explosion hazards you have to assure:

- that the equipment category and group of device correspond to the predetermined zones and environmental parameters
- a working approval was given from the operator
- no explosible atmosphere exists
- the system is power-off to avoid an inadvertently switch-on.

To perpetuate the degree of protection, the measuring system must be protected against electric shock by application.



NOTICE!

All applicable regulations as well as the customer documentation for the respective sensor telemetry system has to be observed.

4.2 Installation of the PickUp Stator Antenna

The pickup stator antenna has to be mounted securely to avoid a mechanical contact with the rotor antenna during operation!

4.3 Installation of the Sensor Signal Amplifier

During installation of the sensor signal amplifier it has to be assured:

- The fastening of the sensor signal amplifier, the sensors and the cable has to correspond to the mechanical load.
- The intrinsically safe sensor signal amplifier is grounded either direct or with a capacitor Cg as a low resistance HF-connection.
- The safe sensor signal amplifier is mounted on top or inside a measuring transducer (e.g. shaft). It has - proportional to the amplifier - a large surface area and a large volume, which is used to absorb and radiate the heat generated by the amplifier.



NOTICE!

Special hints in the customer documentation has to be observed!

4.4 Installation of the Evaluation Unit



NOTICE!

The tabletop unit or rather the compact evaluation unit has to be grounded at declared grounding points.

4.5 Installation of the Grounding and Potential Equalization



CAUTION!

Grounding is mandatory to avoid stray electrical currents across the coaxial cable shield.



NOTICE!

Use the declared grounding points at the pickup stator antenna and the evaluation unit.

4.6 Dismounting of the Sensor Telemetry System

For the dismounting of the system the terms as described [↗ Further information on page 26](#), 4.1 Preparation for Mounting has to be observed!

Disposal

The operator is responsible for the disposal in accordance with applicable rules, unless specific return or disposal agreement has been made.

5 Further Information



For specific installation information mind the customer documentation.

Service

It must be included in the system maintenance plan to verify that the Manner telemetry system is functioning properly for the application. Corresponding functional tests can be found in the enclosed customer documentation.

Disturbances

The enclosed customer documentation contains instructions for troubleshooting. If the fault can not be eliminated, the telemetry system is to set out of operation.

6 Contact

The customer, as the builder of a system with an integrated sensor telemetry system, is responsible for the correct and conform operation and accepts the responsibility for operation in accordance to the currently valid Low Voltage Directive.



MANNER Sensortelemetrie GmbH

Eschenwasen 20

D - 78549 - Spaichingen

Tel.: +49 7424 9329-0

Fax: +49 7424 9329-29

www.sensortelemetrie.de

info@sensortelemetrie.de

Appendix

A Declaration of Conformity

EU Declaration of Conformity Directive 2014/34/EU (ATEX)

Manufacturer:

Manner Sensortelemetrie GmbH
Eschenwasen 20
78549 Spaichingen, Germany

Product:

Telemetry system consisting of evaluation unit, stator antenna and sensor signal amplifier

Types:

AW_PCM16_Ex
Ant_G_PCM_Ex
MSV_G_K_T_Ex

and their variants in accordance with the EU Type Examination Certificate

Manner Sensortelemetrie GmbH hereby declares under its sole responsibility that the above-described product complies with the relevant Union harmonisation legislation, in particular Directive 2014/34/EU.

The equipment category and marking are in accordance with the EU Type Examination Certificate.

Applied harmonised standards:

EN IEC 60079-0:2018

– Explosive atmospheres: General requirements

EN 60079-11:2012

– Explosive atmospheres: Equipment protection by intrinsic safety "i"

The specific conditions for safe use are defined in the EU Type Examination Certificate.

EU Type Examination Certificate:

TÜV SÜD Product Service GmbH
Ridlerstraße 65, 80339 Munich, Germany
TPS 23 ATEX 075617 0006 X
Notified Body (No. 0123)

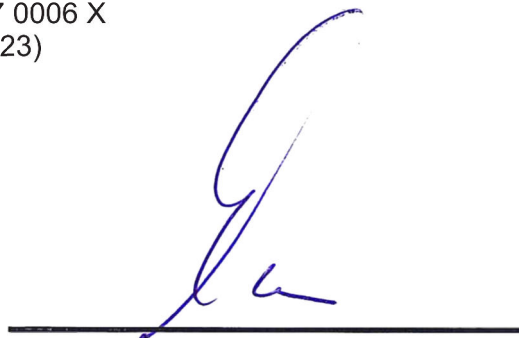

Dr. Ernst Manner, CEO
Spaichingen, 29.04.2026